



60Hz

GOVOX-U Series, these vortex pumps feature a less impeller wear and longer pump life by a vortex flow that allows fibrous materials and solid matters to be pumped out without obstruction.

Sewage Pump

GOVOX-U 322/337

Vortex Pump



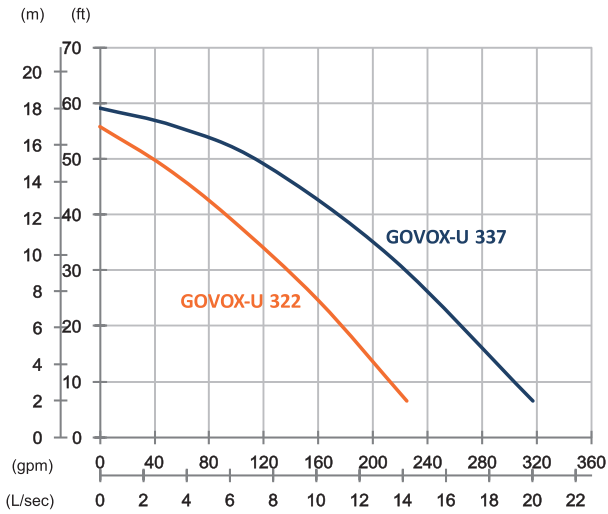

| | GOVOX-U 322 | GOVOX-U 337 |
|----------------------|--|---|
| OUTPUT | 3 HP (2.2 kW) | 5 HP (3.7 kW) |
| OUTLET | 3" (80 mm) | 3" (80 mm) |
| SOLID PASSAGE | 2.2" (55 mm) | 2.2" (55 mm) |
| Weight | 88 lbs/40 kg | 108 lbs/49 kg |
| HEAD | Rated: 39 ft, 12 m Max: 56 ft, 17 m | Rated: 49 ft, 15 m Max: 59 ft, 18 m |
| FLOW | Rated: 95 gpm, 6 L/s Max: 225 gpm, 14.2 L/s | Rated: 119 gpm, 7.5 L/s Max: 317 gpm, 20 L/s |

| | | |
|-------------------------------------|----------------------|-----------------------------------|
| Pump Type | | Electric Submersible Pumps |
| Motor | Phase | 3-Phase |
| | Type | Induction Motor |
| | Poles | 2 Pole (3450 rpm) |
| | Insulation | Class F |
| | Protector | Circle Thermal Protector |
| | Starter | D.O.L. |
| Lubricant | | Food Grade (ISO VG32) |
| Specs. | Impeller Type | Vortex |
| | Shaft Seal | Double Mechanical Seal |
| | | Silicon Carbide VS Ceramic/Carbon |
| | Bearings | C3 Shielded ball bearings |
| | Cable | CSA-Certified PVC Jacketed Cables |
| 33 ft (10 m) or longer upon request | | |
| Materials | Pump Casing | Ductile Iron |
| | Impeller | Gray Iron |
| | Motor Frame | Gray Iron |
| | Motor Shaft | Stainless Steel |
| Max. Liquid Temperature | | 40°C (104°F) |
| Max. Submersion Depth | | 20 m (66 ft) |
| pH Range | | pH 5 - pH 8 |

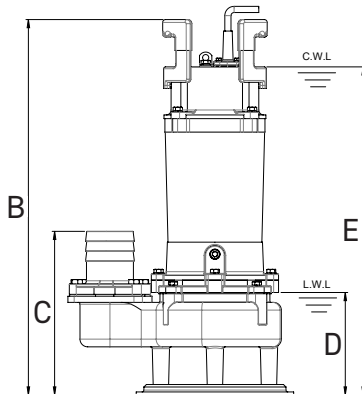
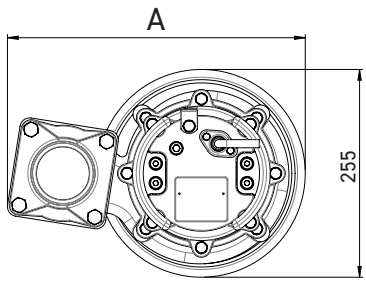

| | A | B | C | D | E |
|-------------|-----|-----|-----|-----|-----|
| GOVOX-U 322 | 366 | 660 | 265 | 150 | 531 |
| GOVOX-U 337 | 376 | 717 | 274 | 159 | 589 |

unit : mm

C.W.L : Continuous running water level
L.W.L : Lowest running water level